



I EN Installation and Operating Manual

Radio module UNI-EO

- Please pass on to the user -

About this manual

- Read this manual carefully and completely before assembly! Always observe the general safety instructions and the safety symbols with information in the text.
- Hand out this manual to the user (tenants, proprietors, property management etc.) after completing assembly.



This symbol warns you against risks of injury



This symbol warns you against risks of injury from electricity

Safety instructions



Caution! Any assembly work may only be carried out after disconnecting the supply voltage!



Attention! The electric connection may only be made by authorised qualified personnel and according to the applicable version of VDE 0100!

Disposal



The packaging must be sorted before disposal. If you wish to dispose of the ventilation device, observe the currently applicable regulations. Pursuant to the German Electrical and Electronic Equipment Act (ElektroG) this device can be returned to your municipal collection point free of charge.

Technical data UNI-EO

| | |
|------------------------------|--|
| Operating voltage: | 3.3V DC |
| Power consumption (module) : | < 1W |
| Radio frequency: | 868 MHz |
| Range: | up to 40 meters (free field) |
| Operating temperature: | 0°C / 40°C |
| EPP profile: | D2-50 (for coupling with radio control centre) |
| Dimensions: | 44mm x 23mm x 13mm |

Installation on the universal control 5/UNI-FT

The radio module is plugged onto the 6-pole connector of the 5/UNI-FT. Make sure that all poles are correctly connected.

When installing in the flush-mounted box, the antenna should be positioned in the direction of the opening, if possible.

If a switch is installed on the control at the same time, it must always have priority. The operating mode Slave is excepted.

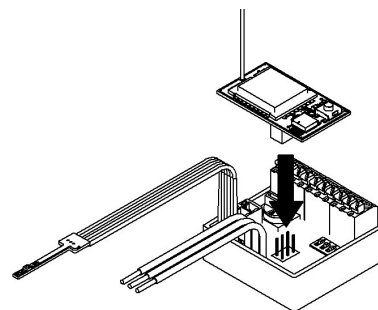

DIP-switches - Display

DIP switch 1:
ON: Slave mode
OFF: Stand-alone operation (standard)
DIP 1 must be set before commissioning!

DIP switch 2:
ON: Outdoor sensor
OFF: Indoor sensor (standard)

DIP switch 3:
ON: Radio master
OFF: - (standard)

DIP switch 4:
ON: Transmit mode
OFF: Receive mode (standard)

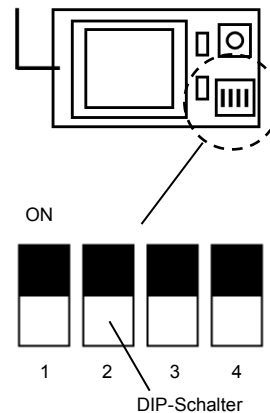

DIP switches - Description

DIP switch 1:
In stand-alone mode, buttons / sensors / other fans can be coupled as signal transmitters. Slave mode only in connection with a SmartHome central unit or a 5/UNI-FT with UNI-EO module in Master mode (see DIP 3)

DIP switch 2:
Used to teach additional sensors (see teaching SFT-EO)

DIP switch 3:
Configured as radio master, the module transmits the switched stage and the operating mode (heat recovery or summer ventilation) to coupled UNI-EO modules with Slave mode setting (see DIP 1). The reversing time is synchronised cyclically.

DIP switch 4:
If an exhaust fan (e.g. RA 15-60 or E⁹⁰) is connected to the universal control 5/UNI-FT, the radio module will transmit the operating stage to coupled UNI-EO or FM-EO radio modules in order to actively convey supply air.

Coupling mode

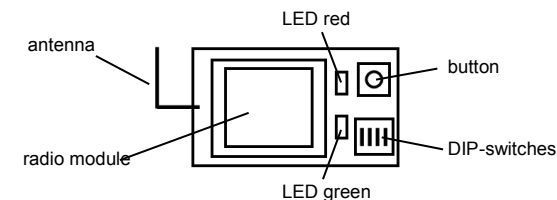

To teach further radio components to the radio module UNI-EO, it must be set to coupling mode. To do this, press and hold the button for 5 seconds. To simplify matters, the LED lights up green every second during this time. Release the button after 5s. The module is now in coupling mode, indicated by the red LED lighting up every second.

The coupling mode is automatically terminated after 30 s if no coupling process has taken place.

Radio remote control RC-EO

For coupling the RC-EO radio remote control, set the UNI-EO module to coupling mode as described above. Then press the "+" button on the RC-EO three times within 2 seconds. If the coupling process was successful, the red LED will stop lighting and the green LED will confirm the process by lighting up five times.

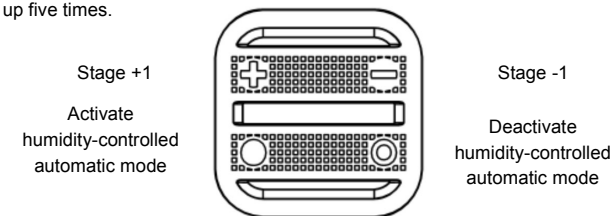

The summer ventilation is activated by simultaneously pressing the buttons "+" and "I" and deactivated by simultaneously pressing "-" and "o". The filter is reset by pressing the "-" button five times within 5 seconds while fan stage 0 is active.

Humidity and temperature sensor SFT-EO

For coupling, the housing of the SFT-EO sensor must be opened. To do this, loosen the two screws on the bottom. Only one indoor and one outdoor sensor can be coupled per UNI-EO module. DIP switch 2 of the UNI-EO must be set to ON (outdoor sensor) or OFF (indoor sensor) and the module must be set to coupling mode as described above.

To couple the SFT-EO sensor, press the button on the bottom of the solar cell one time. If the process is successful, the red LED of the UNI-EO will stop lighting and the green LED will confirm the process by lighting up five times. The humidity and temperature sensor of the 5/UNI-FT is still active even when the indoor sensor is coupled. In automatic mode, the higher humidity value of the two sensors is used for control operation.

If an outdoor sensor is connected, the difference between indoor and outdoor air humidity above 50% RH in the interior is used for intelligent control.

Radio module FM-EO and Silvento ec

For active exhaust air compensation, a 5/UNI-FT with UNI-EO radio module can be coupled to the FM-EO radio module of a Silvento ec.

To do this, set DIP switch 4 of the FM-EO to ON and set the UNI-EO radio module to coupling mode as described. Now press the button on the FM-EO one time.

If the coupling process is successful, the red LED of the FM-EO will go out and the green LED will light up five times for confirmation.

If the Silvento ec is now set to a regulated ventilation stage higher than 30m³/h, the devices connected to the universal control will compensate the resulting negative pressure with 15m³/h per device, i.e., two e² units convey 30m³/h, four units a total of 60m³/h.

Radio module FM-EO and Ne^{xx}t

If an exhaust fan is operated on the 5/UNI-FT of the UNI-EO (e.g. RA15-60, eGO or similar) and a Ne^{xx}t with an installed FM-EO radio module on the supply air side, these can be coupled.

If the exhaust fan is then set to one stage higher than 30m³/h, the Ne^{xx}t will compensate this with 30m³/h sole supply air operation.

For coupling, DIP switch 4 on the UNI-EO module must be set to ON.

The Ne^{xx}t with installed FM-EO must first be set to coupling mode. To do this, please refer to the installation instructions for the FM-EO radio module.

With the coupling mode of the FM-EO activated, press the UNI-EO button one time to do the coupling. If the coupling process is successful, the coupling mode on the FM-EO will be terminated.

Exhaust air compensation 5/UNI-FT (A) by 5/UNI-FT (B)

This requires two universal controls 5/UNI-FT, each of which is supplemented by one UNI-EO radio module. One 5/UNI-FT (A) is installed on the exhaust air side (kitchen, WC, bathroom, etc.) and controls a RA 15-60 or E⁹⁰ devices. An additional 5/UNI-FT (B) is installed on the supply air side (living room, bedroom or children's room) and controls devices of the type e².

By coupling the two controls, the 5/UNI-FT (B) will switch to active supply air operation of 15m³/h per connected unit if the 5/UNI-FT (A) is switched to exhaust air operation with an airflow volume higher than 30m³/h.

To couple the two controls, set DIP switch 4 of the UNI-EO of the 5/UNI-FT (A) to ON. Set the UNI-EO radio module of the 5/UNI-FT (B) to coupling mode as described above and then press the button of the 5/UNI-FT (A) one time.

If the coupling process is successful, the red LED of the UNI-EO of the 5/UNI-FT (B) will go out and the green LED will light up five times for confirmation.

Master-Slave operation of two 5/UNI-FT (preconditions)

Two universal controls 5/UNI-FT, each supplemented by a UNI-EO radio module, are required for this. The following conditions apply:

- Slave 5/UNI-FT can only mirror states
- The setting of the coding switches of both controls must be identical.
- DIP switches of Slave 5/UNI-FT must be in 0-position.
- Slave must not be coupled with TAC / button / switch / gesture control or similar. The wires for connecting a switch (grey, red, black) must be individually insulated.
- The Slave control does not count any filter or operating time.
- One Master control can control several Slave controls. One Slave can only be controlled by one Master.
- In total across all controls, the same number of devices must be operated at the outputs S1 and S2.

Master-Slave operation of two 5/UNI-FT (coupling)

To couple the two controls, DIP switch 3 on the UNI-EO of the Master control must be set to ON. On the UNI-EO module of the Slave control, DIP switch 1 must be set to ON and the other DIP switches of the module must be set to OFF.

The UNI-EO of the Slave control must now be set to coupling mode as described above. Then press the button of the UNI-EO of the Master control one time.

If the coupling process is successful, the red LED of the UNI-EO of the Slave control will go out and the green LED will light up five times for confirmation.

Decoupling of two radio components

To disconnect two coupled radio components, the component to be decoupled from must be switched to decoupling mode. To do this, keep the button of the component pressed for 15s. The LED will light up every second during this time. Release the button after 15s. The LED will continue to flash green.

Now confirm the disconnection on the component to be decoupled.

- FM-EO (Silvento ec), UNI-EO, SFT-EO: Press button one time
- FM-EO (Ne^{xx}t): Press the "Radio" button on the control element of the Ne^{xx}t one time
- RC-EO: Press the "+" button three times within 2 seconds

If the decoupling is successful, the green LED of the UNI-EO will go out and the red LED will light up five times for confirmation.

Notes

Notes

Notes